

MINIATURE COUPLING MOUNTING INSTRUCTIONS

SERIES: DKN - DK/S

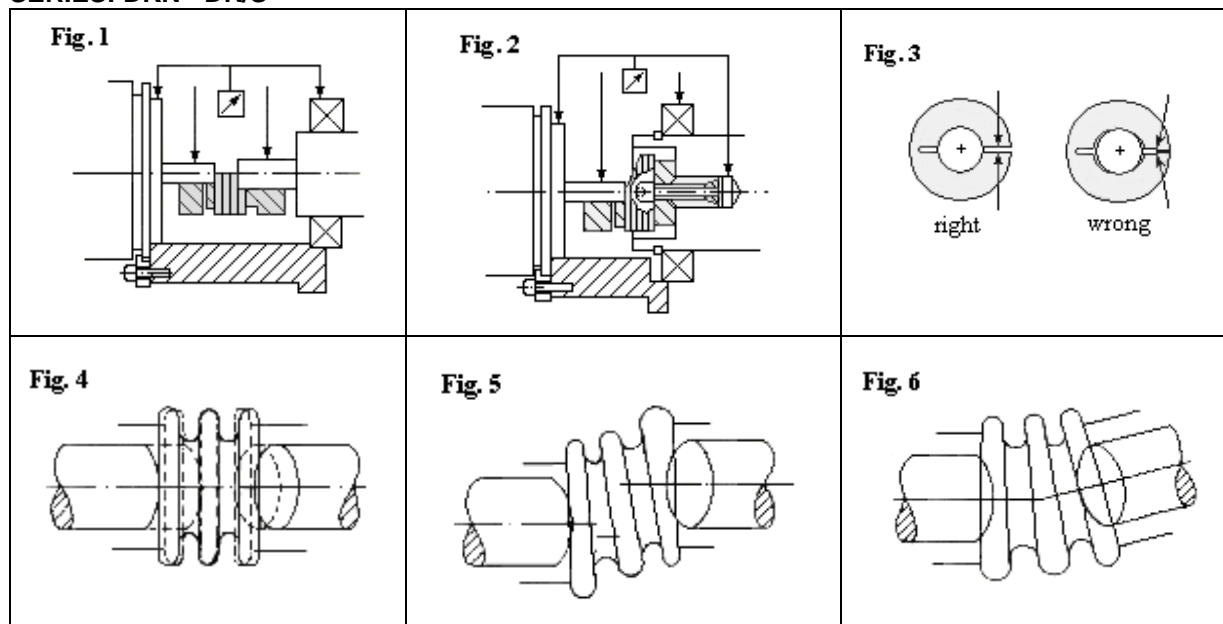

MOUNTING:

1. Check shafts for misalignment, ratings shown in tables (**Figs. 1,2**).
2. Check dimensional accuracy of fits: series DKN and DK/S with "H7/f7" tolerance.
3. Align metal bellows couplings on shafts.
4. Carefully tighten straining screws/clamping screws: avoid excessive tightening (**Fig. 3**).
5. Protect coupling from damage and too much bending during mounting work.

BEARING LOADS:

Bearing loads occur mainly when the driving shaft is misaligned with respect to the driven shaft. To prevent bearing wear, Rimtec metal bellows couplings are used to connect them. They compensate for shaft misalignment in axial (0.2-0.5mm), lateral (0.1-.25mm), and angular (1.2°-2°) directions (**Figs. 4, 5, 6**). The restoring forces involved are negligibly small. All the data regarding shaft misalignment apply for permanent limit values: ambient temperature -20° to +100°C (higher ambient temperatures for military and aerospace applications to order).

PRECISION IN TRANSMISSION:

Rimtec miniature metal bellows couplings are characterized by high torsional stiffness and are free from backlash. These features allow exact angular transmission between drive input and drive output, particularly during alternating loads.

DISTORTION VIBRATION:

Rimtec miniature metal bellows couplings work as a homokinetic transmission joint. Changes in angular speed, caused by unequal angle transmission or excessively low torsional stiffness, are precluded by the careful selection of the coupling. For applications in closed-loop circuits (controlled shaft movements), special attention is paid to the existing high torsional stiffness. Further details on the ratings and special application conditions may be obtained from the manufacturer.

ROTATION SPEED:

Rimtec couplings have a very low mass moment of inertia and light weight. To ensure no slipping, a clearance of 0.03mm is maintained between shaft and clamping hub. The couplings are also suitable for use at high rotational speeds of 10,000 rpm and above.

LIFE:

When properly rated and applied, Rimtec metal bellows couplings are highly durable. Overloading the couplings with a torque in excess of $M=2.5M_N$ may cause destruction of the metal bellows. Likewise the life of the coupling may be impaired on exceeding the shaft misalignments stated in paragraph 1.

RIMTEC CORPORATION
211 S. Lombard Road, Addison, IL 60101
Toll Free: 877-4RIMTEC (877-474-6832)
Tel: 630-628-0036, Fax: 630-628-0041
E-mail: info@RimtecCorporation.com
Web Site: <http://www.RimtecCorporation.com>